



HAND-HELD LASER CLEANING MACHINE

The Hand-held Laser Cleaning Machine is the most flexible and ergonomic hand-held laser cleaner on the market. You can easily reach any area, change the laser configuration and move the workstation around. You get a cost-effective solution that allows you to process multiple parts of different shapes and sizes.

This off-the-shelf Class-4 laser cleaning system is available in different power levels ranging from 50W to 500W. It includes the right features to keep your workers safe, and its fume extraction nozzle ensures the continuous removal of contaminants from the work area.



ERGONOMIC DESIGN

Based on the proven chainsaw design, our Hand-held laser offers natural grips and movements for cleaning operations. Its buttons are readily accessible, allowing operators to easily trigger the laser and modify the beam's width and orientation.

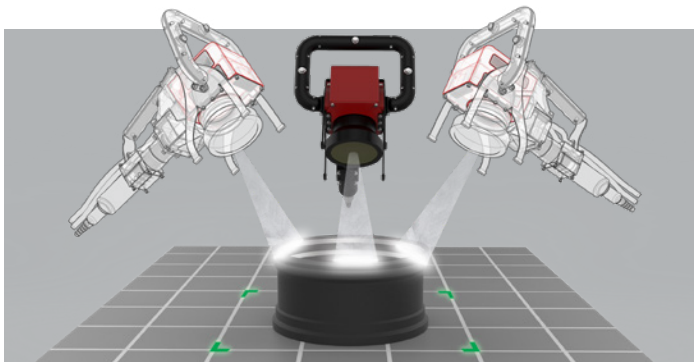

HIGHLY FLEXIBLE CLEANING

With its wide range of gripping positions, the Hand-held laser can get into zones that would otherwise be difficult to reach. As a mobile solution, it is ideal if you need to clean multiple parts or large ones.



SAFETY FEATURES & TRAINING

The laser comes with the right safety features, including a dual-action safety guard, a remote interlock, light warnings and laser safety eyewear. Our laser safety experts also provide the required training to ensure the safe usage of the laser cleaning equipment.



GREEN TECHNOLOGY WITH FAST ROI

When you clean with light, you don't use any chemical products or blast media. The cleaning process is environmentally friendly and provides a clean work environment for your operators. You also eliminate important operation and purchase costs related to consumables.

TECHNICAL SPECIFICATIONS

HAND-HELD LASER CLEANING MACHINE

Laser Power	50 to 500W
Laser Type	Ytterbium-doped fiber
Wavelength	1064 nm
Laser Source MTBF	100,000 hours
Laser Process	Cleaning & Texturing
Typical Weight	5.9 kg
Cooling	Air cooling (water cooling with 500W)
Power Requirements	120V, 230V, 240V / 15-40 AMP
Power Consumption	1.5 kW to 5.8 kW
Operating Temperature	10°C to 45°C
Cleaning Modes	6 modes, selectable directly from hand-held head
Part Material	Aluminium, Zinc, Magnesium, Steel, Iron (All Metals)
General Dimensions (W x D x H)	Head : 250 x 500 x 270 mm Station : 670 x 740 x 2000 mm



TYPICAL DIMENSIONS

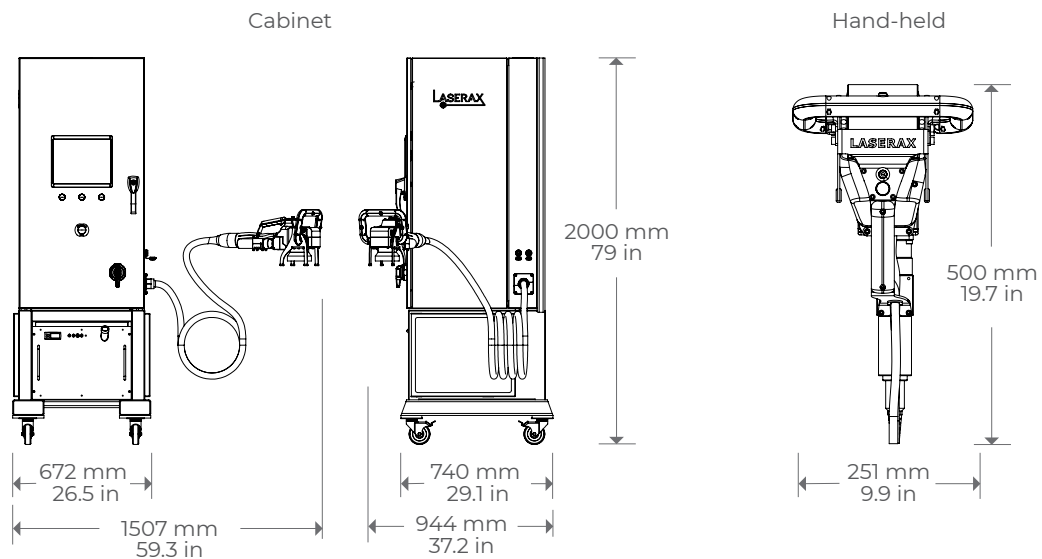

INDUSTRIAL LASER SOLUTIONS
VISIT LASERAX.COM

LASERAX HEADQUARTERS

101-2811 Watt Ave
Quebec, QC G1X 4S8
Canada
+1 418 780-7324

LASERAX USA

2401 Parkman Road
Warren OH 44485
United States
+1 412 301-9957

LASERAX GMBH

Fehrenheitstraße 1
28359 Bremen
Germany
+49 421 2208-121